

BRACKETS AND FITTINGS

FACE FIX BRACKETS FOR SYSTEM 30 All dimensions are in mm

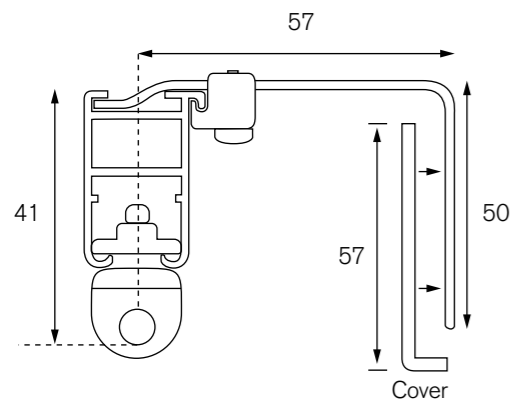

Standard bracket

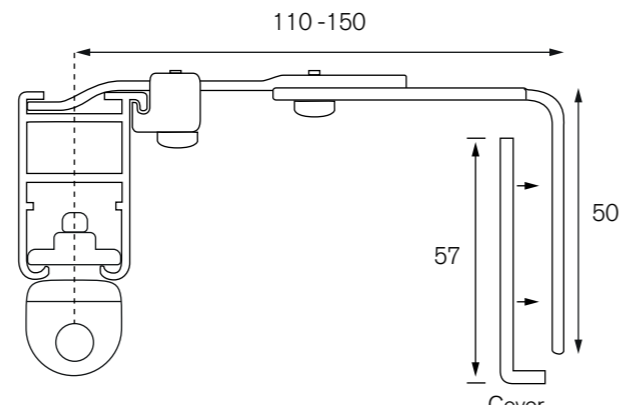

Heavy duty adjustable 110 -150 bracket

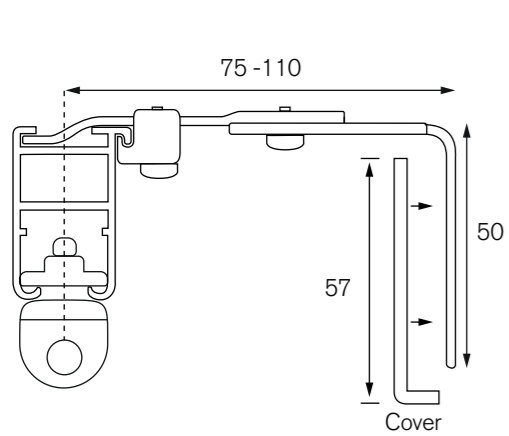

Heavy duty adjustable 75 -110 bracket

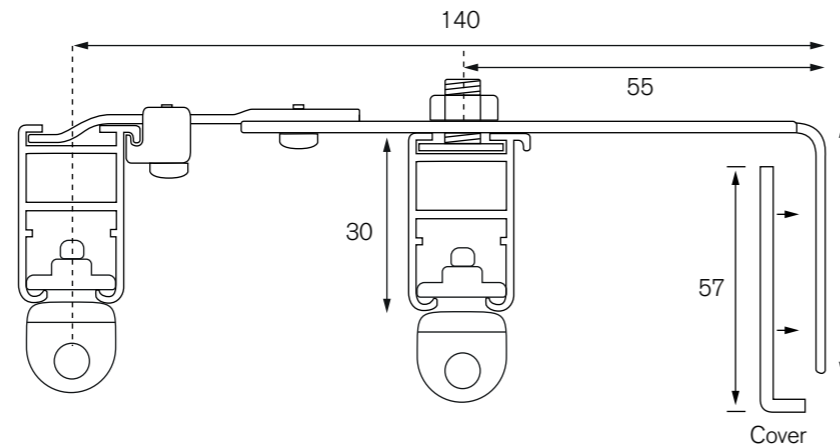

Double track bracket

DIRECT CEILING FIX

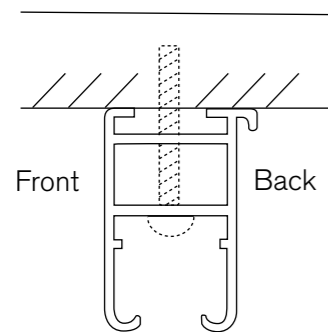

DRAWROD CARRIER

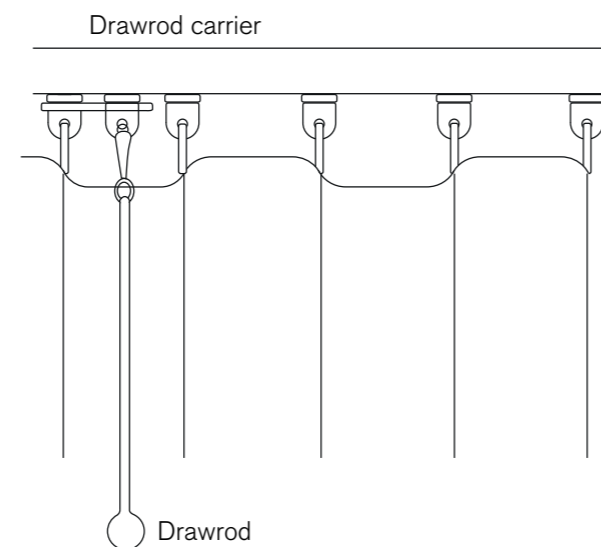

CameronFuller

Curtain Poles and Track

SYSTEM 30 BENDABLE CURTAIN TRACK

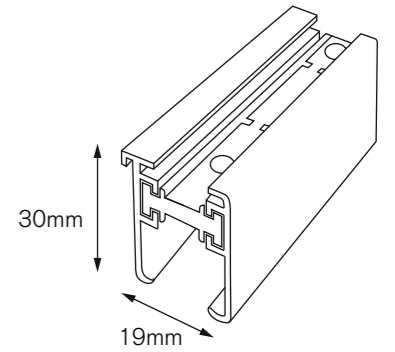

Bend on site at point of installation.

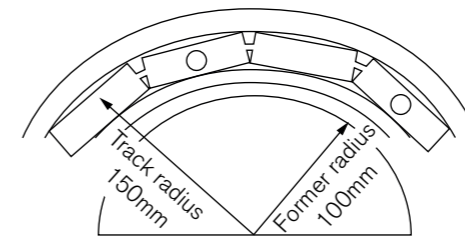
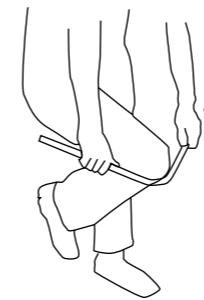

Former with spring back gives a track bend radius of 150mm (we can supply this former)

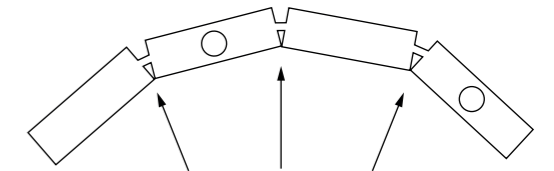

Bend track until kerfs touch. Do not bend any further

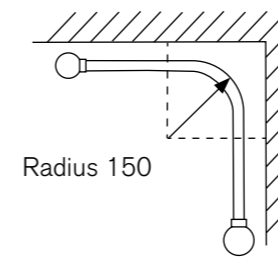

FORWARD BENDS

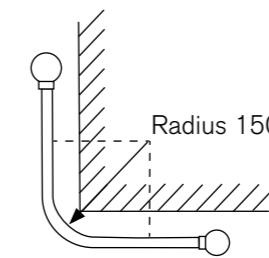

REVERSE BENDS

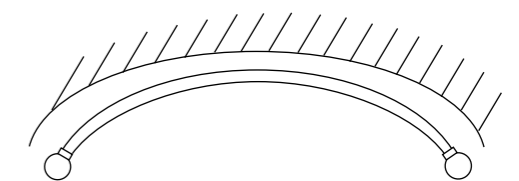

CONTINUOUS BENDS

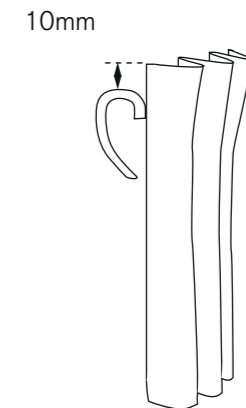
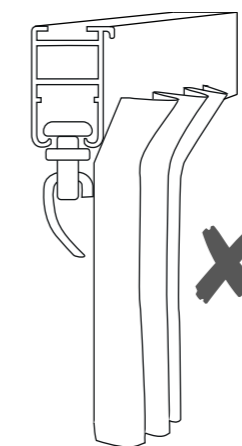
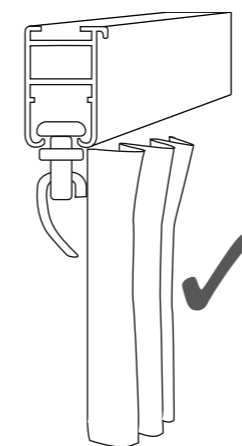

Curtain headings should be underslung to ensure the best operation of the curtains

BENDING SYSTEM 30 TRACK AROUND A BAY WINDOW

1 All tracks over 3.0m long are supplied in 2 pieces. The track should be joined in the middle of the centre window, on a straight section of track.

2 Insert centre joiner, pushing the plastic filler down the track. Ensure the magnet is at the front of the track. Tighten the locking screws

3 Bend from the centre working outwards. Bend A, then B, then C. Complete each bend before moving on to the next bend.

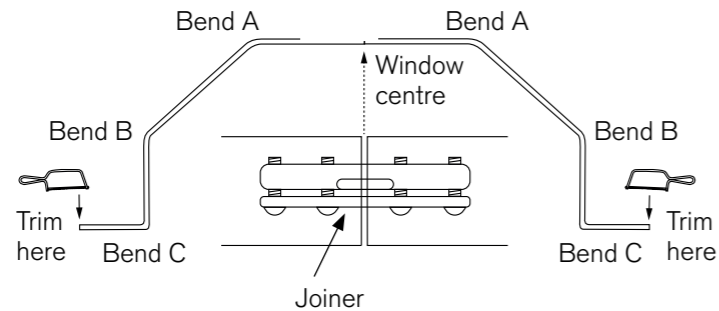
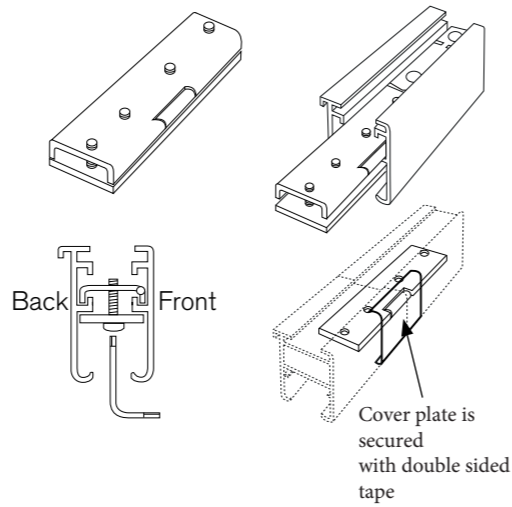
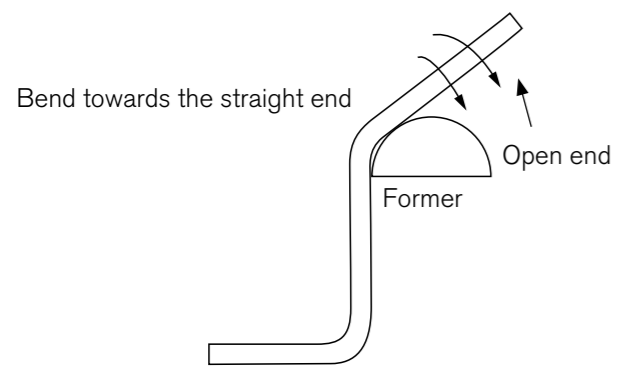
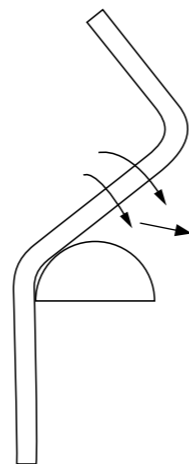

Diagram shows track joiner attaching two track lengths at the window centre

Always bend the track towards an open end



NOT LIKE THIS
DO NOT try to bend towards another bend
This method causes internal stress in the track which can cause the gliders to jam



4 Because the centre joiner has been inserted and tightened any unevenness in the track lengths should now be at the end of the track which can be trimmed or covered with the end cap

5 Fit this part of the track to the wall/ceiling using a fixing to either the wall or ceiling every 60cm as shown:

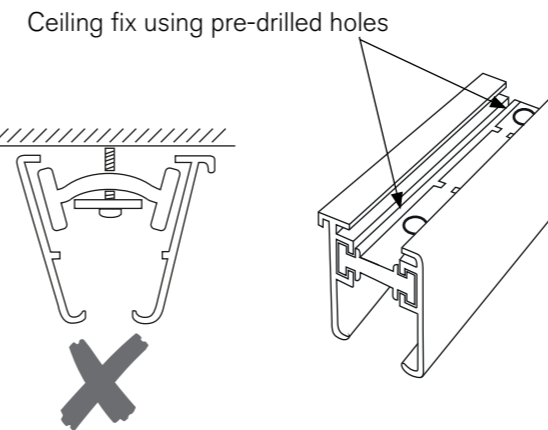
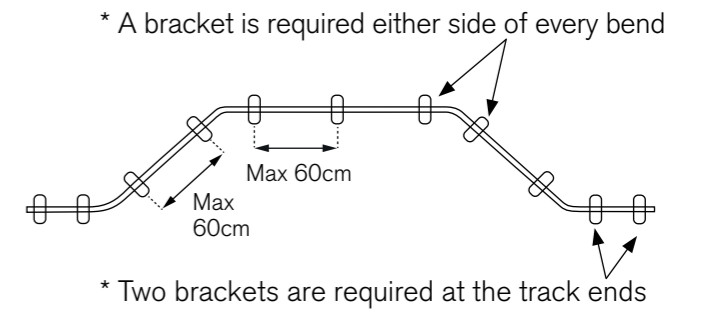

When top fixing bendable track, DO NOT over tighten screws as this can deform the track and cause the gliders to jam

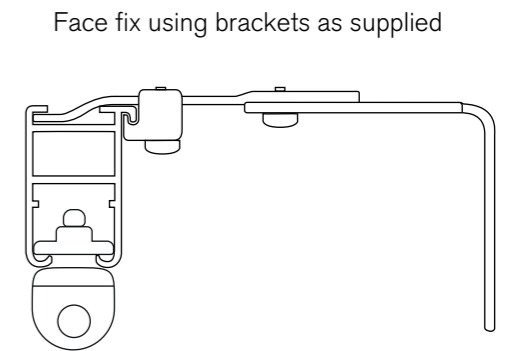

6 Remove the centre joiner and insert into the other half of the track, tighten the locking screws and bend angle A B anC . Again because the joiner is tightened up any unevenness in the track will be at the end which can be trimmed or covered with the end cap.

7 Trim end of the track and join to the half of the track already installed, using the centre joiner. track should be butted together tightly with no gap showing.

8 At each side, slide all but one of the gliders onto the track, insert the end stops, tighten near the end of the track and then slide on the last glider. Push on the end caps/finials and secure with the allen key provided

9 Clip the centre cover plate over the join in the centre of the track.